

HOBART

WM-2E

COVERS CM1E

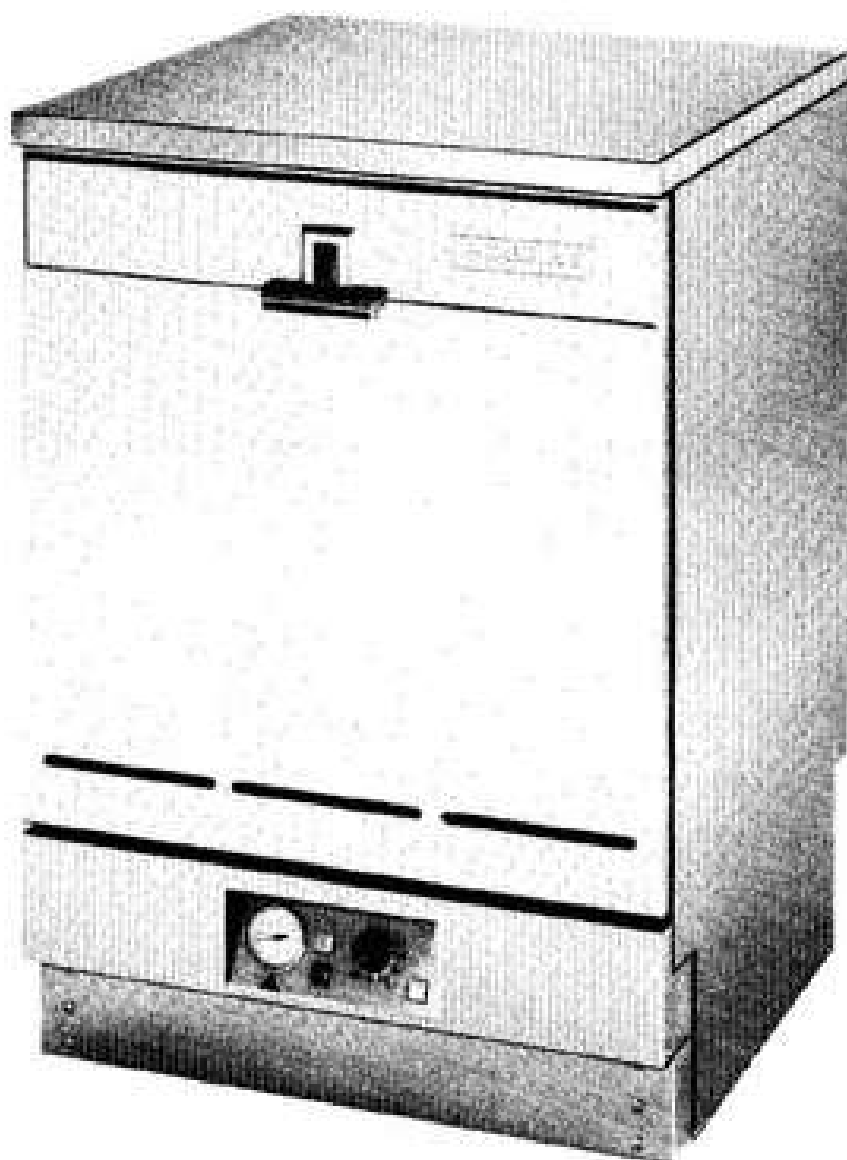



Frame and Side Panels
Chassis et Habillages
Gestell und Verkleidungen

WM-2E

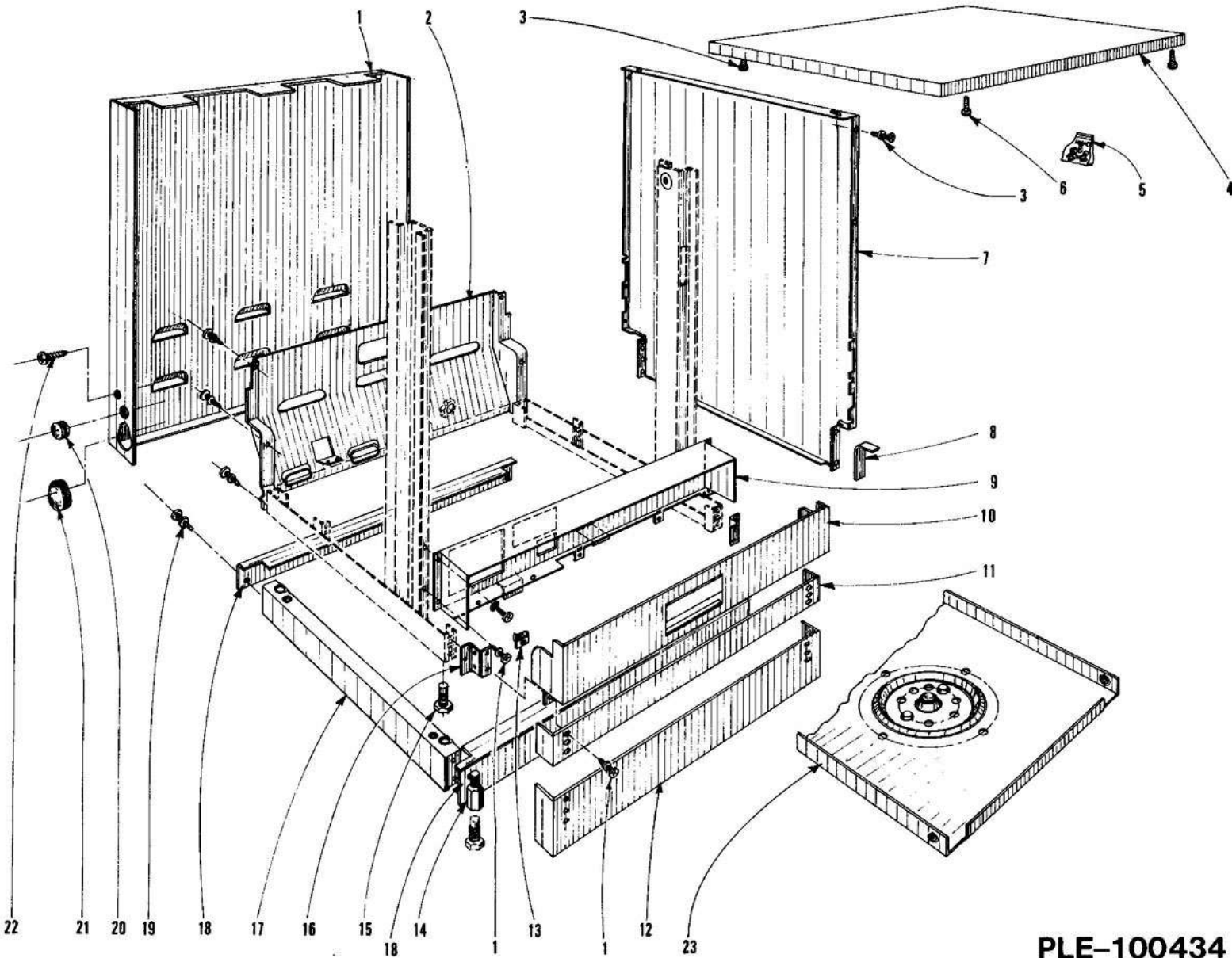

PLE-100434

key no. réf. Pos.-Nr.	part no. pièces no. Teile-Nr.	part name nom de la pièce Teile-Benennung	qty. qté. Stck.
1	E-172577	rear panel assy.(850 mm) habillage arrière (850 mm) Rückverkleidung (850 mm)	1
	E-172602	(900 mm)	1
2	E-228029	rear panel assy. panneau arrière, ens. Rückwand komplett	1
3	B-227624-1	ABC spax screw vis ABC spax ABC Spax Schraube	2
4	C-228067	top, assy. (incl. item No. 3) plateau, ens. (compr. réf. 3) Abdeckplatte, kompl. (inkl. Teil Nr. 3)	1
5	B-268267	bag sachet en plastique Plastikbeutel	1
6	SD-26-09	self-tapping screw No. 10 x 1/2" truss. phil. hd. vis à tôle B à empreinte cruciforme No. 10 x 1/2" Flachrund-Blechschaube 4,8 x 13	2
7	E-228043	side panel (R.H. or L.H.) panneau latéral gauche ou droit seitliche Verkleidung, rechts oder links	2
8	B-168834-2	sealing tie ruban d'étanchéité Dichtband	2
9	D-228040	mounting plate, assy. plaque de montage, ens. Montageplatte	1
10	D-228057	lower panel, assy. habillage inférieur, ens. untere Frontverkleidung, kompl.	1
11	E-227773	extension piece socle Sockel	1
12	D-228178	extension piece - front (for 900 mm height) socle frontal (dans le cas d'une haut. de 900 mm) Sockel - Frontverkleidung (bei 900 mm Höhe)	1
13	C-227228-1	speed nut écrou rapide Blechmutter	4
14	B-227539	threaded spacer bolt (for 900 mm height) entretoise filetée (dans le cas d'une haut. de 900 mm) Zwischenstück mit Gewinde (bei 900 mm Höhe)	4
15	B-226945	foot levelling bolts pied réglable Verstellfuß	4
16	B-227766	bracket console Konsole	2
17	D-227547	extension piece (R.H. or L.H.) (for 900 mm) socle latéral, droit ou gauche (900 mm) Sockel - Seitenteil, rechts oder links (900 mm)	2
18	D-227553	front and rear panel in case of 900 mm socle avant et arrière dans cas machine à 900 mm Front- und Rückverkleidung (900 mm)	2
19	SA-11-8	self-tapping screw, pan hd. and lockwasher, assy. vis auto-tar. TR, à empreinte cruciforme, et rondelle DE Linsen-Blechschaube mit Kreuzschlitz und Fächerscheibe	24
20	A-165073	small rubber plug petit bouchon en caoutchouc kleiner Gummistopfen	1
21	A-165072	big rubber plug grand bouchon en caoutchouc großer Gummistopfen	1
22	SD-26-09	self-tapping screw No. 10x1/2" truss. phil. hd. vis à tôle TB à empreinte cruciforme no.: 10x1/2" Flachrund-Blechschaube 4,8x13	2
23	D-227997	bottom panel (only for Germany) tôle du fond (seulement pour l'Allemagne) Bodenblech (nur für Deutschland)	1



Strainer, Washarm, Tank heating and Door End Switch
Filtre, Bras de Lavage, Réchauffage de Bac et
interrupteur de porte
Siebssystem, Wascharm, Tankheizung und Endschalter

WM-2E

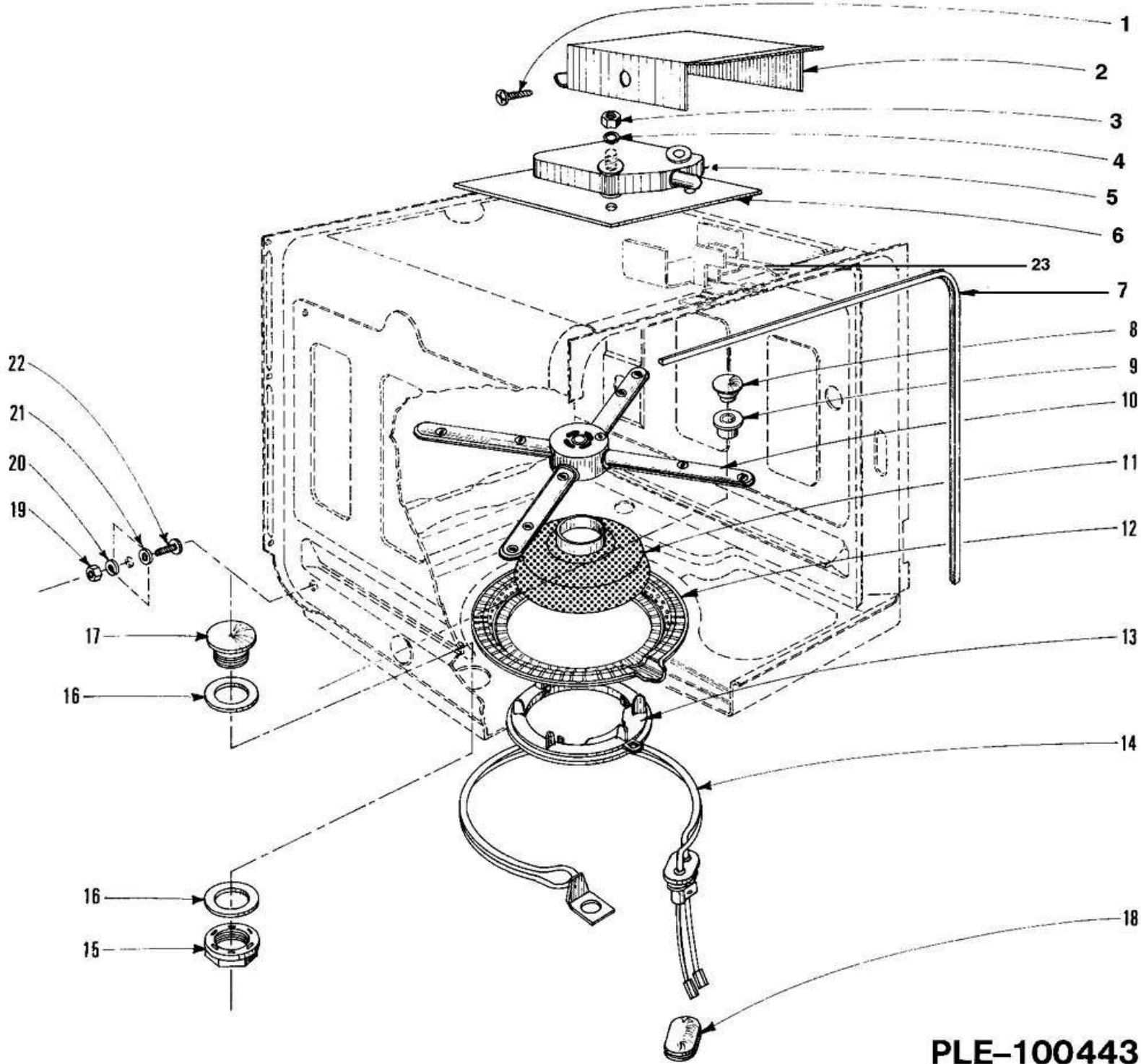

PLE-100443

key no. réf. Pos.-Nr.	part no. pièces no. Teile-Nr.	part name nom de la pièce Teile-Benennung	qty. qté. Stck.
1	SD-17-13	self-tapping screw, mushroom hd. No. 10 x 1/2" vis à tôle B, auto-tar., à empreinte cruciforme Flachrund-Blechschrabe mit Kreuzschlitz	2
2	227966	cover couvercle Abdeckung	1
3	NUM-E-2-11	hex. nut M 4 (s.st.) écrou H M 4 (inox) Sechskantmutter M 4 DIN 934-A2	1
4	LWM-E-2-2,	single coil lockwasher M 4 (s. st.) rondelle WZ (inox) Federring B 4 DIN 127-1,4310	1
5	227947	door end switch interrupteur de porte Türendschalter	1
6	227965	isolating plate plaque isolante Isolierplättchen	1
7	227060	gasket-tank seal joint de porte Türdichtung	1
8	240162	plug button bouchon Stopfen (WM-2E: WS 4,5 – 6/D 4,5 – 6)	1
9	240163	gasket-plug button Joint de bouchon Dichtung – Stopfen (WM-2E: WS 4,5 – 6/D 4,5 – 6)	1
10	228082	wash arm assy. ensemble bras de lavage Wascharm, kompl.	1
11	226607	fine strainer filtre à fines mailles Feinsieb	1
12	226608	coarse strainer filtre à grosses mailles Grobsieb	1
13	115479-1	seat fine strainer siège du filtre fin Sitz des Feinsiebs	1
14	227949-1	tube heating element résistance chauffante Rohrheizkörper 220-240 V (WS/WS4,5 – 6)	1
15	227592	special plastic nut écrou spécial en matière plastique Kunststoff-Mutter	1
16	226813	gasket joint Dichtung	2
17	165926	plug button bouchon Stopfen	1
18	165100	plug (in case of D models without tank heating) bouchon (en cas de modèles D sans réchauffage) Stopfen (bei D-Modellen ohne Tankheizung)	1
19	NUM-E-3-2,	hex. nut M 6 écrou H M6 (galv.) Sechskantmutter M6 DIN 934-8 GAL.ZN. 5BK	1
20	LWM-E-3-1,	single coil lockwasher M 6 (galv.) rondelle WZ 6 (galv.) Federring B6 DIN 127 GAL. ZN. 5BK	1
21	227087	gasket washer rondelle joint Dichtungsscheibe	1
22	SCM-E-5-2,	recessed pan head screw M 6x10 (s.st.) vis R M 6x10 (inox) Linsenschraube A M 6x10 DIN 7985-A2	1
23	227963	lever door end switch	



Motor, Washpump and Drain Unit
Ensemble Moteur, Pompe de Lavage et Vidange
Motor, Waschpumpe und Ablauf-Einheit

WM-2E

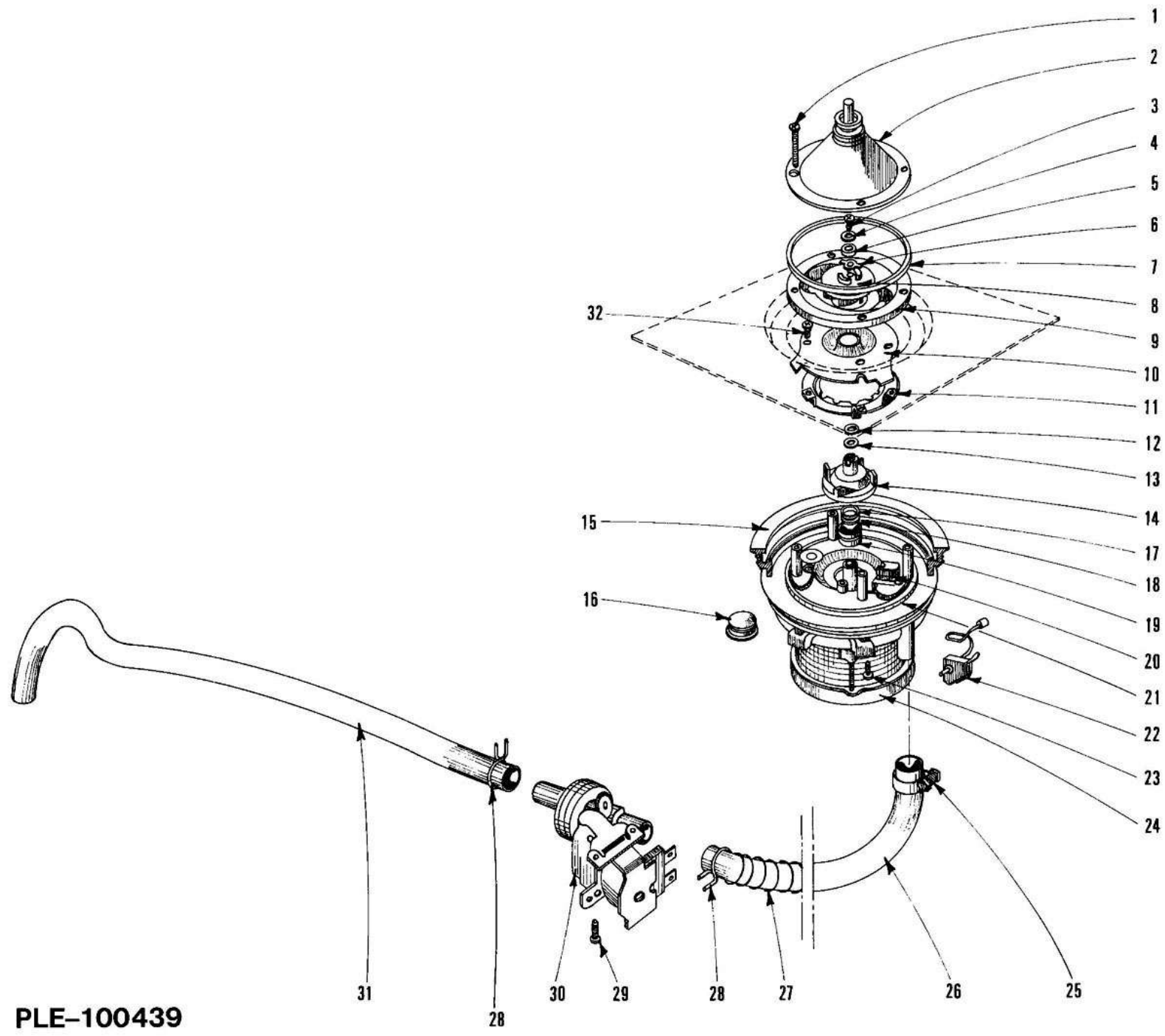

PLE-100439

key no. réf. Pos.-Nr.	part no. pièces no. Teile-Nr.	part name nom de la pièce Teile-Benennung	qty. qté. Stck.		
1	SC-80-13	mach. screw No. 10-24 x 7/8" fil. hd. vis machine CBL à empreinte cruciforme Linsenzylinderschraube mit Kreuzschlitz	4		
2	C-227957	cover-pump couvercle de pompe Pumpendeckel	1		
3	SC-66-19	mach. screw No. 10-32 x 7/16" truss. hd. vis CB à empreinte cruciforme Flachrund-Blechschrabe mit Kreuzschlitz	1		
4	M-83752	spring washer - impeller rondelle ressort de turbine Federscheibe - Laufrad	2		
5	A-107114	cap - motor shaft embout - axe du moteur Abdeckung - Motorachse	1		
6	M-81492	washer key - impeller shaft rondelle de blocage - axe de turbine Blockierscheibe - Laufradachse	1		
7	C-115684	ring gasket - wash pump joint circulaire de pompe de lavage Dichtungsring - Waschpumpe	1		
8	D-226944	wash impeller turbine de lavage Laufrad - Waschung	1		
9	E-115468	lower pump housing corps de pompe inférieur Pumpengehäuse	1		
10	C-115681	cover - inlet couvercle d'entrée Pumpeneingangsdeckel	1		
11	D-115453	top - drain pump dessus de pompe de vidange Oberteil - Ablaufpumpe	1		
	B-240359	washer shim cale rondelle Distanzscheibe	0.030" thk. 0.030" ép. 0,030" dick	(0,8 mm) (0,8 mm) (0,8 mm)	A.R. S.B. N.B.
12	B-240360	washer shim cale rondelle Distanzscheibe	0.015" thk. 0.015" ép. 0,015" dick	(0,4 mm) (0,4 mm) (0,4 mm)	A.R. S.B. N.B.
	B-240361	washer shim cale rondelle Distanzscheibe	0.005" thk. 0.005" ép. 0,005" dick	(0,13 mm) (0,13 mm) (0,13 mm)	A.R. S.B. N.B.
13	D-67500-30	«O» ring joint torique O-Ring			1
14	D-227741	impeller - drain turbine de vidange Schleuderrad - Ablauf			1
15	D-115716	gasket - motor mounting plate joint du flasque de moteur Dichtung der Motorplatte			1
16	C-116276	plug overhead spray bouchon obturateur (du jet supérieur) Stopfen (oberer Wascharm)			1
	B-240357	washer shim cale rondelle Distanzscheibe	0.005" thk. 0.005" ép. 0,005" dick		A.R. S.B. N.B.
17	B-240358	washer shim cale rondelle Distanzscheibe	0.015" thk. 0.015" ép. 0,015" dick		A.R. S.B. N.B.
	B-240356	washer shim cale rondelle Distanzscheibe	0.030" thk. 0.030" ép. 0,030" dick		A.R. S.B. N.B.
18	B-240229	washer shim cale rondelle Distanzscheibe	0.048" thk. 0.048" ép. 0,048" dick		A.R. S.B. N.B.
19	C-115710	seal shaft joint d'axe circulaire Gleitringdichtung			1
20	C-115525	top half drain channel pièce insertie Einlage			1



Motor, Washpump and Drain Unit
Ensemble Moteur, Pompe de Lavage et Vidange
Motor, Waschpumpe und Ablauf-Einheit

WM-2E

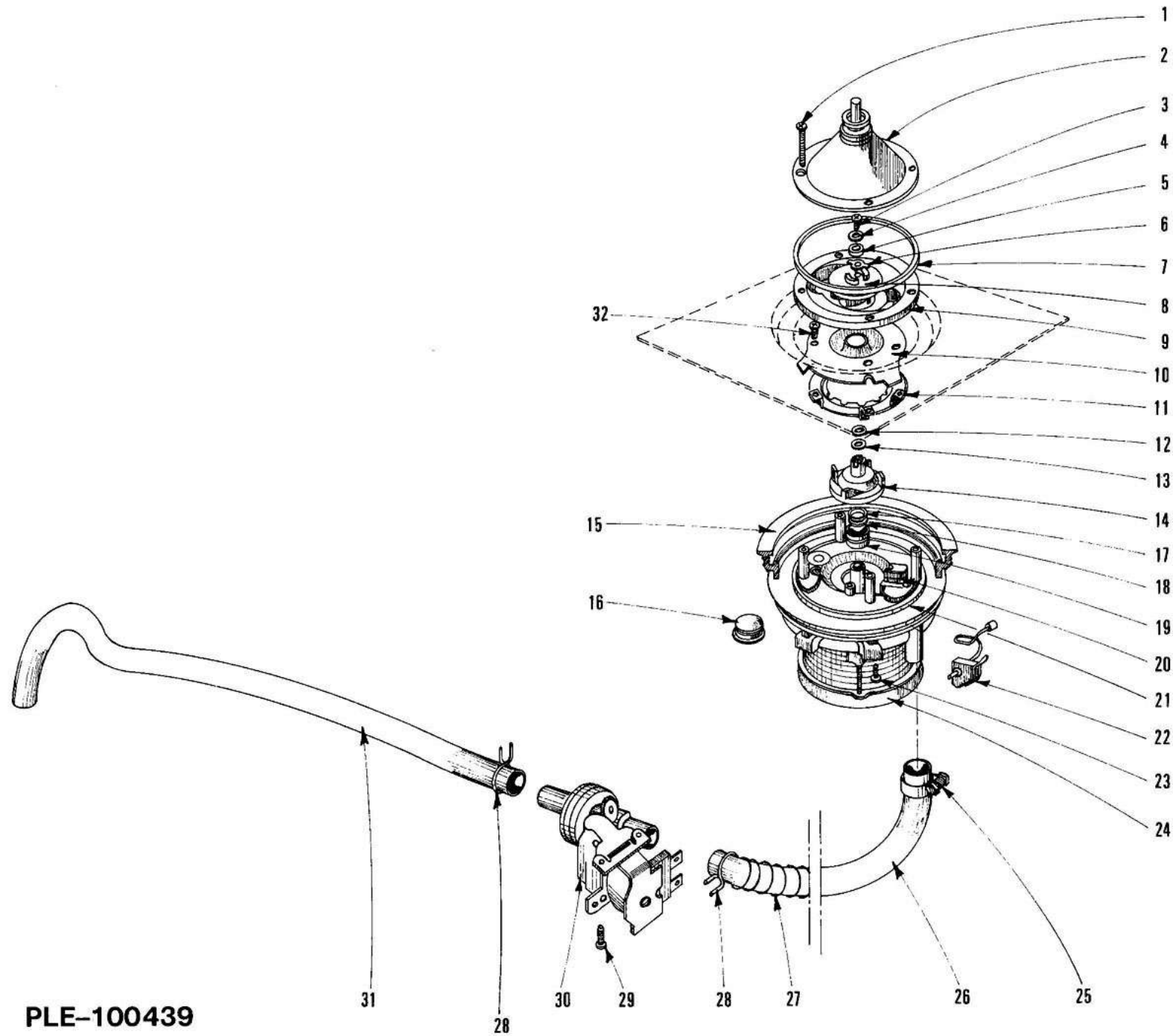

PLE-100439

HOBART

Motor, Washpump and Drain Unit
Ensemble Moteur, Pompe de Lavage et Vidange
Motor, Waschpumpe und Ablauf-Einheit

WM-2E

key no. réf. Pos.-Nr.	part no. pièces no. Teile-Nr.	part name nom de la pièce Teile-Benennung	qty. qté. Stck.
21	E-115718	plate - motor mounting flasque de retenue du moteur Motor-Montageplatte	1
22	C-240106	clamp assy. - motor retaining ensemble crochet de retenue du moteur Motorhalterungsklammer	3
23	SC-18-71	mach. screw 1/4" - 20x1 vis à machine Maschinenschraube	4
24	E-226481-1 E-226481-2	motor moteur Motor	220/50/1 240/50/1 1 1
25	C-240202-3	clamp hose collier à tuyau Schlauchschelle	1
26	C-115758	tube - flexible 1/2" - 14" long tube flexible 1/2" - 14" long Schlauch 1/2" - 14" lang	1
27	P-82924	spring coil (drain tube) ressort de protection Feder	1
28	M-102004-2	clamp hose collier à tuyau Schlauchschelle	2
29	SD-17-14	self-tap. screw No. 10-1/2" truss. hd. vis auto-tar. B à empreinte cruciforme Flachrund-Blechschaube mit Kreuzschlitz	2
30	D-240248-3	valve drain électrovanne de vidange Ablaufventil	220/50/1 1
30	D-240248-2	valve drain électrovanne de vidange Ablaufventil	240/50/1 1
31	C-227927	drain hose tuyau de vidange Ablaufschlauch	1
32	SC-93-4	mach. screw No. 8-32 x 1/2" pan hd. phil. rec. vis à tôle TR à empreinte cruciforme Linsen-Blechschaube mit Kreuzschlitz	1
	E-227761-1	Pump and motor system assy (incl. items No. 1 to 21,23,24) ensemble pompe de lavage et moteur Pumpe und Motor, kompl. (inkl. Teile Nr. 1 - 21,23,24)	220/50/1 1
	E-227761-2	pump and motor system assy. (incl. items No. 1 to 21,23,24) ensemble pompe de lavage et moteur Pumpe und Motor, kompl. (inkl. Teile Nr. 1 - 21,23,24)	240/50/1 1



Mounting Plate with Electrical Parts
Tableau de Bord avec Auxiliaires électriques
Montageplatte mit Elektro-Teilen

WM-2E

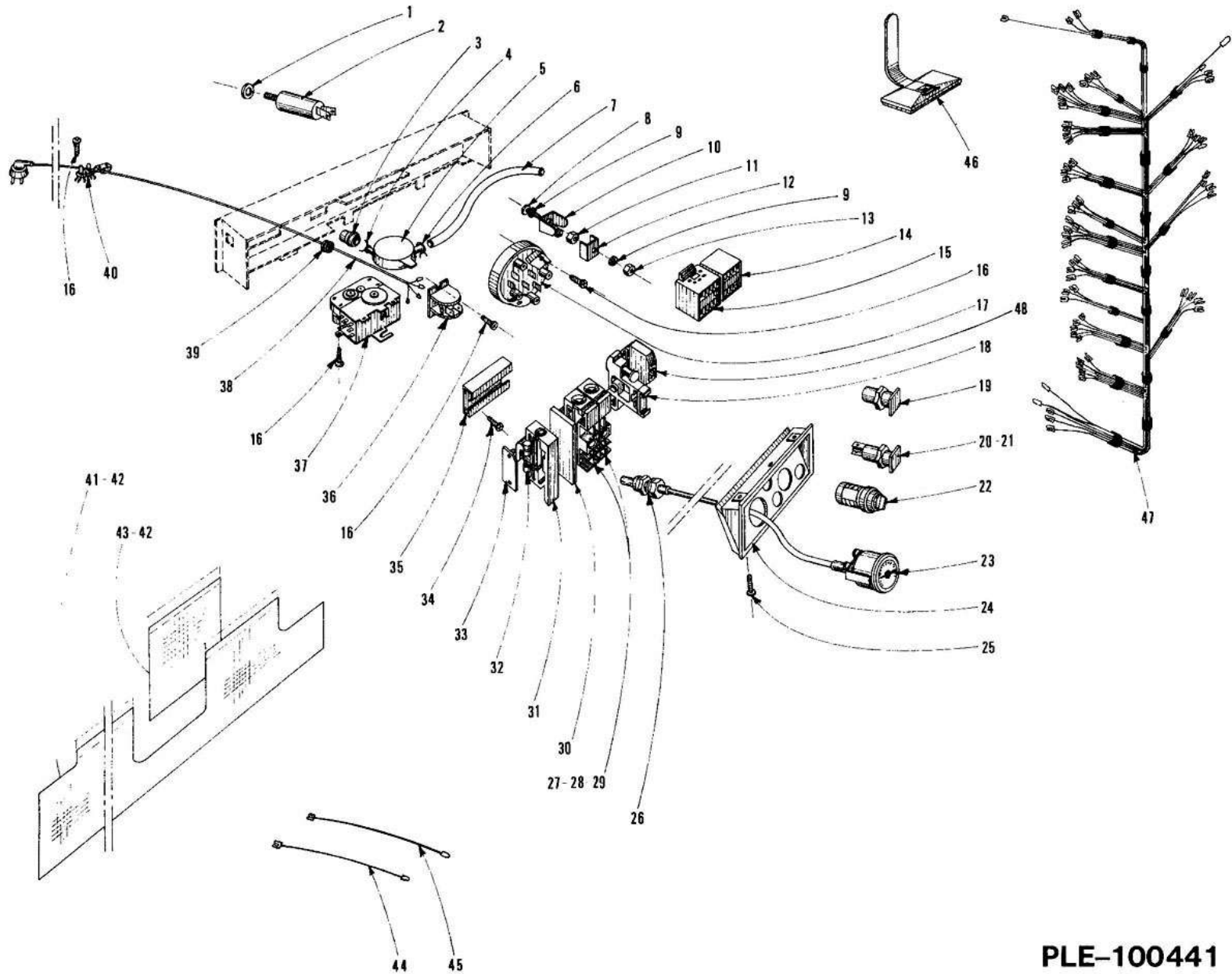

PLE-100441

key no. réf. Pos.-Nr.	part no. pièces no. Teile-Nr.	part name nom de la pièce Teile-Benennung	qty. qté. Stck.
1		WAM-E-8-34, plain washer M 8 (s.st.) rondelle M 8N (inox) Scheibe A 8 DIN 125-A2	1
2	C-226954	condenser condensateur 14 μ F Kondensator	1
3	B-167306	hose (air room - tank) tuyau (poche d'air au réservoir) Schlauch (Tank - Luftkammer)	1
4	M-86012	hose clamp serre-tuyau Schlauchklemme	1
5	C-167191	air room poche d'air Luftkammer	1
6	M-102087	hose clamp serre-tuyau Schlauchklemme	1
7	A-166072-4	hose (air room - pressure switch) tuyau (poche d'air au pressostat) Schlauch (Luftkammer - Druckschalter)	1
8		SCM-E-11-14, recessed pan hd. screw M 4x16 (s.st.) vis R M 4x16 (inox) Linsenschraube M 4x16 DIN 7985-A2	1
9		toothed lockwasher M 4 rondelle DE 4 Zahnscheibe A 4,3 DIN 6797	2
10	B-226814	triple cable shoe cosse de terre triple Erdungsleiste	1
11	A-166081	NUM-E-2-2, hex. full nut brass M 4 écrou H, laiton M 4 Messingmutter SK M 4	1
12		clamp strap U de serrage Klemmbügel C 8 DIN 46282, Ms. vern.	1
13		NUM-E-2-11, hex nut M 4 (s.st.) écrou H M 4 (inox) Sechskantmutter M 4 DIN 934-A2	1
14	C-228015-1	contactor contacteur 220/50/1 (WM-2E: WS 4.5-6/D 4.5-6) Schütz	1
14	C-228015-3	contactor contacteur 240/50/1 (WM-2E: WS 4.5-6/D 4.5-6) Schütz	1
15	C-228015-2	contactor auxiliary contacteur auxiliaire 220/50/1 WS/WS4.5-6/D 4.5-6 Behelfsschütz	1
15	C-228015-4	contactor auxiliary contacteur auxiliaire 240/50/1 (WM-2E: WS/WS 4.5-6/D4.5-6) Behelfsschütz	1
16		recessed pan hd. screw 3.9 x 9.5 vis à tête R 3,9 x 9,5 Linsenblechschraube B 3,9 x 9,5 DIN 7981	7
17	C-226953	double pressure switch pressostat à double effet Doppel-Druckschalter	1
18	B-168282-1	end stop presse-borne WS 4.5 / D 4.5 Endwinkel WS 6 / D 6 220-240/50/1 220/240/50/3	1
19	B-228085	plug pilot lamp bouchon de voyant Blindstopfen	1
20	C-227948-1	pilot lamp, white voyant lumineux, blanc Signalleuchte, weiß	1
21	C-227948-4	pilot lamp, green voyant lumineux, vert Signalleuchte, grün	1
22	D-227740-3	cam switch interrupteur à cames (WM-2E: WS/WS 4.5-6) Nockenschalter	1



Mounting Plate with Electrical Parts
Tableau de Bord avec Auxiliaires électriques
Montageplatte mit Elektro-Teilen

WM-2E

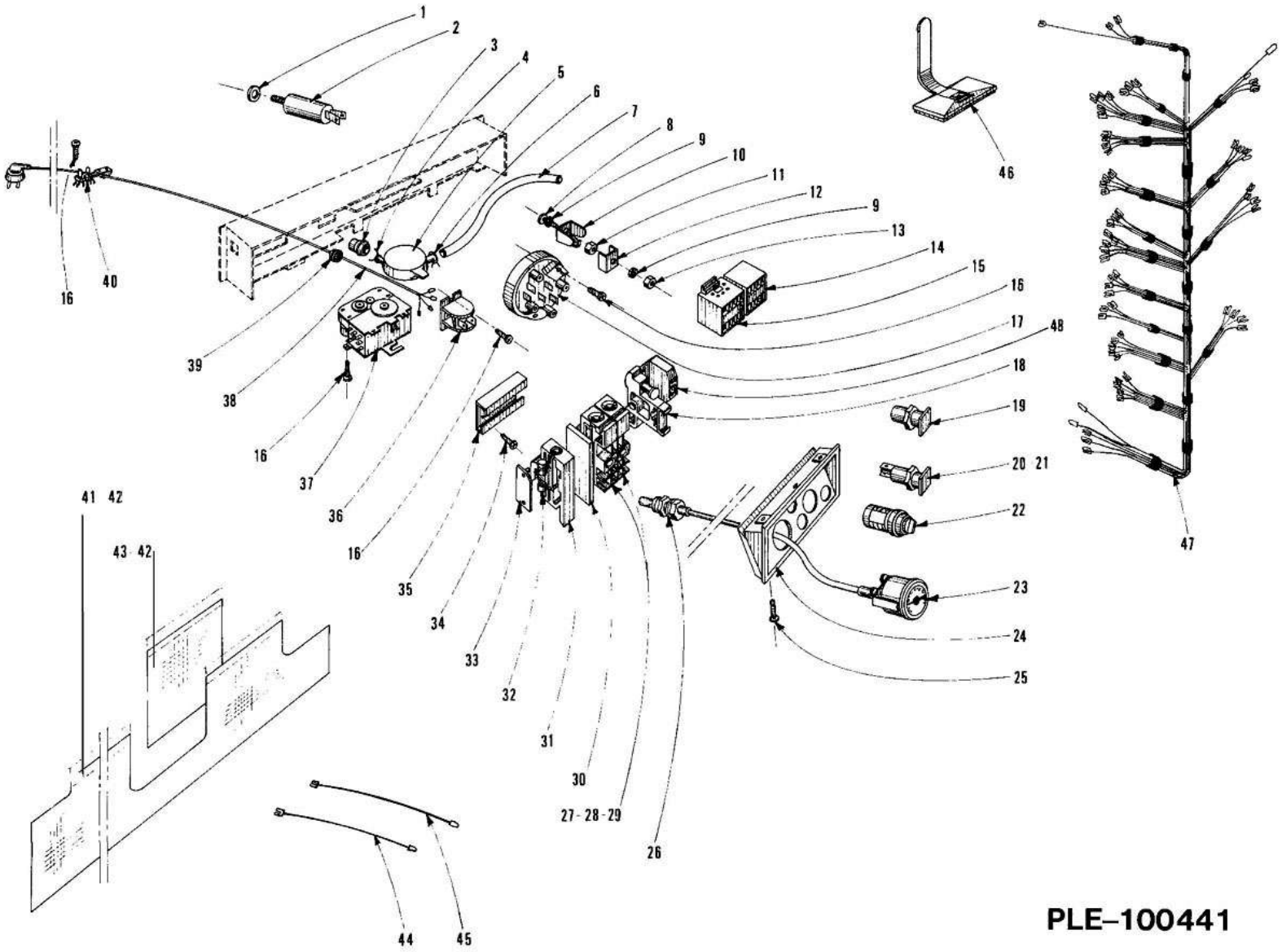

PLE-100441

key no. réf. Pos.-Nr.	part no. pièces no. Teile-Nr.	part name nom de la pièce Teile-Benennung		qty. qté. Stck.
22	D-227740-4	cam switch interrupteur à cames Nockenschalter	(WM-2E: D 4.5-6)	1
23	B-166673	thermometer thermomètre Thermometer		1
24	D-228049-2	control panel body enjoliveur Armaturenblende	(WM-2E: WS/WS 4.5-6)	1
24	D-228049-3	control panel body enjoliveur Armaturenblende	(WM-2E: D 4.5-6)	1
25	SD-17-42	self tap. screw No. 10x1/2" truss. phil. head vis à tôle B à empreinte cruciforme Flachrund-Blechschrabe mit Kreuzschlitz		2
26	B-168611-9	gasket joint Dichtung		2
27	B-228045	terminal borne 220 240/50/1 Reihenklemme	(WS 4.5-6)	2
28	B-168163-2	label - terminal No. 2 étiquette de repérage Einheitsschild	WS 4.5 / D 4.5 220-240/50/1	1
29	B-168163-11	label - terminal No. 11 étiquette de repérage Einheitsschild	WS 4.5 / D 4.5 220-240/50/1	1
30	B-228046	end section plaque terminale Abschlußplatte	WS 4.5 / D 4.5 220-240/50/1	1
31	B-228047	fuse terminal borne à fusible ASK 1 Sicherungsklemme	WS 4.5 / D 4.5 220-240/50/1 WS 6 / D 6 220-240/50/3	1
32	B-226660-3	fuse fusible 6,3 Amp. Sicherung	WS 4.5 / D 4.5 220-240/50/1 WS 6 / D 6 220-240/50/3	1
33	B-228048	end section plaque terminale Abschlußplatte	WS 4.5 / D 4.5 220-240/50/1 WS 6 / D 6 220-240/50/3	1
34		recessed pan head screw 3.9 x9.5 vis à tôle R 3,9 x 9,5 Linsenblechschrabe BZ 3,9 x 9,5, DIN 7982-vern.	(WS 4.5-6 / D 4.5-6)	2
35	B-135891-12	terminal mounting bar profilé support Tragschiene für Reihenklemmen	WS 4.5 / D 4.5 220-240/50/1 WS 6 / D 6 220-240/50/3	1
36	C-226815	MP terminal borne MP MP-Klemme		1
37	D-227735-1	timer minuterie Zeitschaltwerk		1
38	C-228120	power supply cable conduite d'arrivée du courant 220-240/50/1 Anschlußleitung	(WS 4.5/D 4.5)	1
38	C-228111	power supply cable conduite d'arrivée du courant 220-240/50/3 Anschlußleitung	(WS 6 / D 6)	1
38	C-228126	power supply cable conduite d'arrivée du courant 380-415/50/3/N Anschlußleitung	(WS 6 / D 6)	1
38	C-228125	power supply cable conduite d'arrivée du courant 220-240/50/1 Anschlußleitung	(WS)	1
39	B-227748	gland cable passe-fil Kabeldurchführungstülle		1
40	B-227063	strainer relief décharge de traction Zugentlastung		1
41	D-228142	protective sheet film plastique de protection Schutzfolie		1



Mounting Plate with Electrical Parts
Tableau de Bord avec Auxiliaires électriques
Montageplatte mit Elektro-Teilen

WM-2E

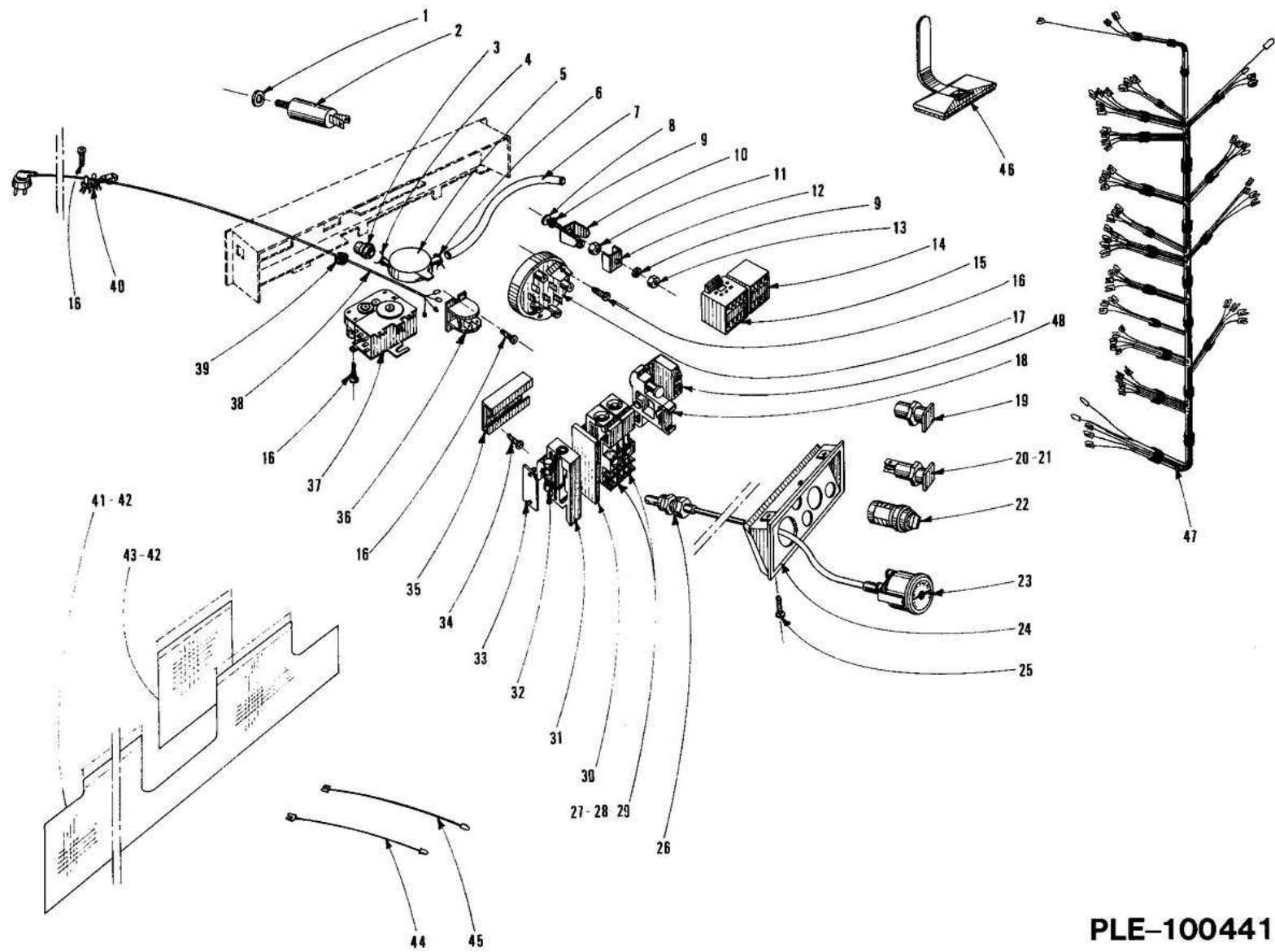

PLE-100441

key no. réf. Pos.-Nr.	part no. pièces no. Teile-Nr.	part name nom de la pièce Teile-Benennung			qty. qté. Stck.
42	B-228140-1	sticking tape ruban adhésif Klebeband			A.R. S.B. N.B.
43	D-228141-1	protective sheet film plastique de protection Schutzfolie			1
44	C-227073-20	bridge pont Brücke	WS 6 / D 6 WS 4.5 / D 4.5	220-240/50/3	3
45	B-228166	bridge pont Brücke	WS 6 / D 6 WS 4.5 / D 4.5	380-415/50/3/N	1
46	A-168094	cable binder serre-câble Kabelbinder			7
47	E-228117	cable wire, assy. faisceau élect., ens. Leitungssortiment		220-240/50/1 (WM-2E: WS 4.5)	1
47	E-228116	cable wire, assy. faisceau élect., ens. Leitungssortiment		220-240/50/1 (WM-2E: D 4.5)	1
47	E-228118	cable wire, assy. faisceau élect., ens. Leitungssortiment		220-240/50/1 (WM-2E: WS)	1
47	E-228113	cable wire, assy. faisceau élect., ens. Leitungssortiment		220-240/50/3 (WM-2E: WS 6 / WS 4.5)	1
47	E-228114	cable wire, assy. faisceau élect., ens. Leitungssortiment		380-415/50/3/N (WM-2E: WS 6 / WS 4.5)	1
47	E-228115	cable wire, assy. faisceau élect., ens. Leitungssortiment		220-240/50/3 (WM-2E: D 6 / D 4.5)	1
47	E-228112	cable wire, assy. faisceau élect., ens. Leitungssortiment		380-415/50/3/N (WM-2E: D 6 / D 4.5)	1
48	C-228180-1	time delay relais temporisé Zeitrelais		220/50/1	1
	C-228180-2			240/50/1	1
	D-227760-4	switching diagram schéma électrique Schaltplan		220-240/50/1 (WM-2E: WS)	1
	D-227760-5	switching diagram schéma électrique Schaltplan		380-415/50/3/N (WM-2E: WS 6 / WS 4.5)	1
	D-227760-6	switching diagram schéma électrique Schaltplan		380-415/50/3/N (WM-2E: D 6 / D 4.5)	1
	D-227750-9	switching diagram schéma électrique Schaltplan		220-240/50/3 (WM-2E: WS 6 / WS 4.5)	1
	D-227760-10	switching diagram schéma électrique Schaltplan		220-240/50/3 (WM-2E: D 6 / D 4.5)	1
	D-227760-13	switching diagram schéma électrique Schaltplan		220-240/50/1 (WM-2E: WS 4.5)	1
	D-227760-14	switching diagram schéma électrique Schaltplan		220-240/50/1 (WM-2E: D 4.5)	1



Door and Front Panel
Porte et Habillage
Tür und Verkleidung

WM-2E

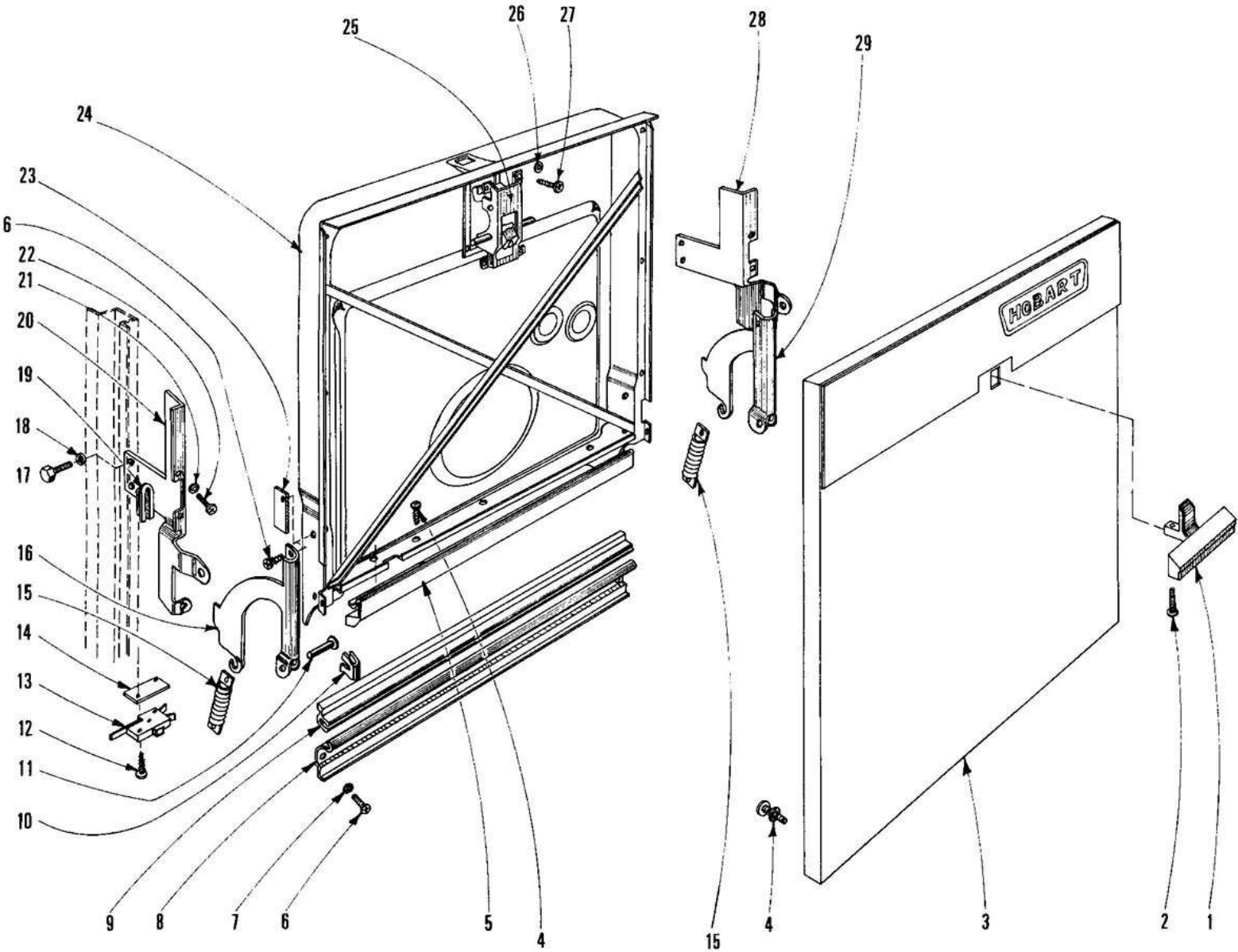

PLE-100435

key no. réf. Pos.-Nr.	part no. pièces no. Teile-Nr.	part name nom de la pièce Teile-Benennung	qty. qté. Stck.
1	E-226958	handle latch poignée Handgriff	1
2	SC-17-18	mach. screw No. 10-32 x 1/2" oval phil. hd. vis à machine FB à empreinte cruciforme Linsensensschraube mit Kreuzschlitz	1
3	D-228028	door panel habillage de porte Türverkleidung	1
4	SA-11-8	self-tapping screw, pan hd. and lockwasher assy. vis auto-tar. R, à empr. cruciforme et rond. DE Linsen-Blechschaube mit Kreuzschlitz und Fächerscheibe	8
5	E-227959	shield door-vapour écran à vapeur Abweisblech	1
6	SC-66-7	mach. screw No. 10-32 x 5/16" truss. phil. hd. vis à tôle B à empreinte cruciforme Flachrund-Blechschaube mit Kreuzschlitz	6
7		toothed lockwasher, M 5 rondelle éventail DE 5 Fächerscheibe A 5,3 DIN 6797	6
8	C-115912	support - evaporation channel support de conduit d'évaporation Halterung der Verdunstrinne	1
9	C-115913	evaporation channel conduit d'évaporation Verdunstrinne	1
10	C-115968	clip retaining clavette de maintien Sicherungsklammer	2
11	B-115910	pin hinge goupille de charnière Scharnierstift	2
12		self-tapping screw, pan. hd. recessed vis à tôle R, à empreinte cruciforme Linsen-Blechschaube mit Kreuzschlitz, B 2,9x16 GAL.ZN.5BK DIN 7981	2
13	B-228002	micro switch interrupteur de porte Mikroschalter	1
14	B-228066	insulating plate plaque d'isolation Isolierplatte	1
15	C-227855	spring - door balance ressort de porte Zugfeder	2
16	D-172543	bracket door stop (L.H.) support de porte, gauche Türhalterung, links	1
17		SCM-E-13-10, hex. head screw M 6x10 (s.st.) vis H M 6x10 (inox) Sechskantschraube M 6x10 DIN 84-A2	4
18		LWM-E-3-1, single coil lockwasher M6 (s.st.) rondelle WZ 6 (inox) Federring B 6 DIN 127-1, 4310	4
19	P-88044	bearing - door stop insert pièce - guide de levier de porte Türscharnier-Führungsteil	2
20	D-172542	bracket hinge (L.H.) charnière support, gauche Türscharnier, links	1
21		LWM-E-3-1, single coil lockwasher M 6 (s.st.) rondelle WZ 6 (inox) Federring B 6 DIN 127-1,4310	4
22		recessed pan head tap. screw M 6x8 vis à tôle R, à empreinte cruciforme M 6x8 Linsen-Blechschaube M 6x8 DIN 7985	4
23	C-228119	identification plate (sticked) étiquette des caractéristiques (collée) Typenschild (geklebt)	1
24	E-227758	inner door, assy. (incl. item No. 25) chassis de porte, ens. (compr. réf. 25) Türgestell, kompl. (inkl. Teil Nr. 25)	1



Door and Front Panel
Porte et Habillage
Tür und Verkleidung

WM-2E

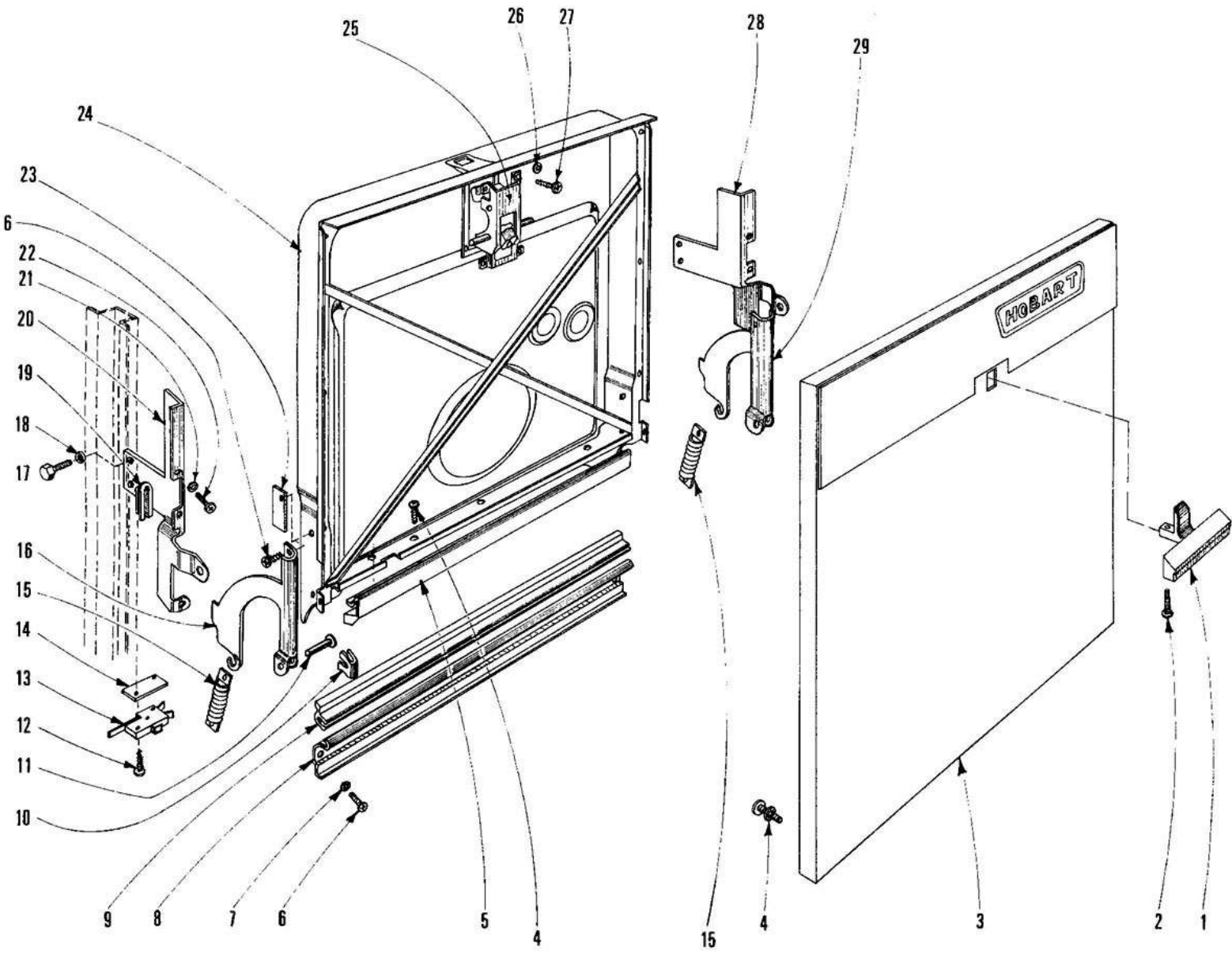

PLE-100435

HOBART**Door and Front Panel
Porte et Habillage
Tür und Verkleidung****WM-2E**

key no. réf. Pos.-Nr.	part no. pièces no. Teile-Nr.	part name nom de la pièce Teile-Benennung	qty. qté. Stck.
25	D-228136	latch mechanism, assy. mécanisme de verrouillage, ens. Verriegelungsmechanismus, kompl.	1
26	WS-2-51	washer space - 13/64 x 1/2 x 1/32 cad. pl. rondelle entretoise Abstandsscheibe	A.R. S.B. N.B.
27	SD-17-14	self-tapping screw No. 10 x 1/2 truss. phil. hd. vis auto-tar. B, à empreinte cruciforme Flachrund-Blechschaube mit Kreuzschlitz	4
28	D-172541	bracket hinge (R.H.) charnière support, droit Türscharnier, rechts	1
29	D-172540	bracket door stop (R.H.) support de porte, droite Türhalterung, rechts	1

HOBART

Booster
Chaudière 4,5 kW - 6 kW
Boiler

WM-2E

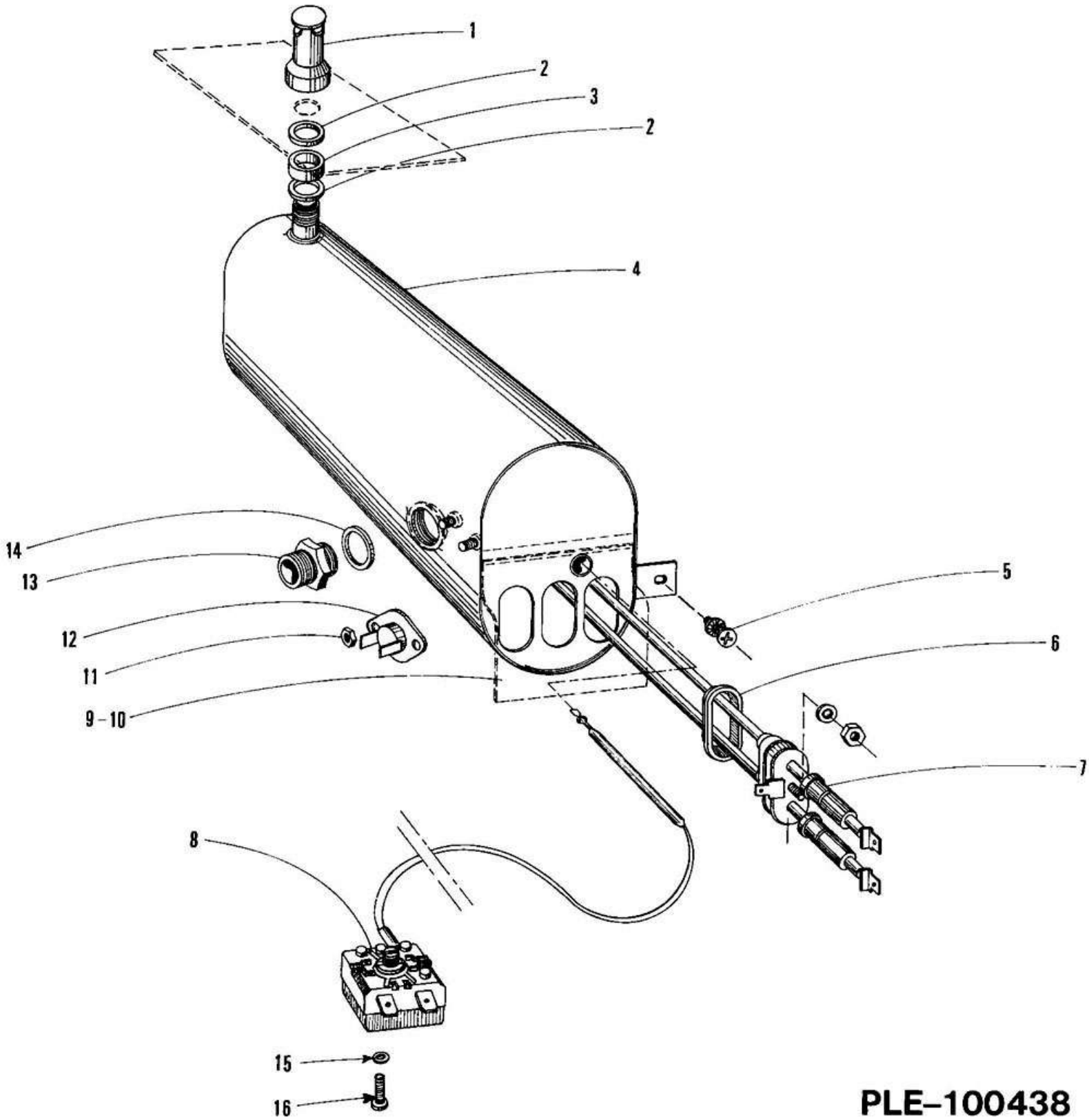

PLE-100438

key no. réf. Pos.-Nr.	part no. pièces no. Teile-Nr.	part name nom de la pièce Teile-Benennung		qty. qté. Stck.
1	B-227767	filler cap pipe de remplissage Einfüllstutzen		1
2	B-168611-3	gasket joint Dichtung		2
3	B-227772	spacer entretoise Distanzstück		1
4	D-227935	booster chaudière Boiler		1
5	SA-11-8	self-tapping screw and lockwasher, assy. vis à tôle et rondelle DE, ens. Blechschaube mit Fächerscheibe, kompl.		1
6	A-166202	gasket - heating element joint du thermoplongeur Dichtung für Rohrheizkörper		1
7	C-165099-1	heating element (incl. item No. 6) thermoplongeur (compr. réf. 6) Rohrheizkörper (inkl. Teil Nr. 6)	1,5 kW, 220/50/1	3
7	C-165099-2	heating element (incl. item No. 6) thermoplongeur (compr. réf. 6) Rohrheizkörper (inkl. Teil Nr. 6)	1,5 kW, 240/50/1	3
7	C-227953-1	heating element (incl. item No. 6) thermoplongeur (compr. réf. 6) Rohrheizkörper (inkl. Teil Nr. 6)	2 kW, 220 V	3
7	C-227953-2	heating element (incl. item No. 6) thermoplongeur (compr. réf. 6) Rohrheizkörper (inkl. Teil Nr. 6)	2 kW, 220 V	3
8	C-226505	thermostat thermostat Temperaturregler	(WM-2E/WS/4,5 - 6)	1
8	C-228145	thermostat thermostat Temperaturregler	(WM-2E/D/4,5 - 6)	1
9	B-228141-1	protecting sheet film de protection Schutzfolie		1
10	B-228140-1	adhesive tape ruban adhésif Klebeband		1
11		NUM-E-2-4, hex. nut, M 3 (s.st.) écrou H M 3 (inox) Sechskantmutter M 3 DIN 934-A2		2
12	B-226504	temperature limiter limiteur de température Temperaturbegrenzer		1
13	B-227931	double nipple mamelon double Doppelnippel		1
14	B-168611-2	gasket joint Dichtung		1
15		WAM-E-8-14, plain washer M 4 (s.st.) rondelle M 4N (inox) Scheibe A 4,3 DIN 125-A2		2
16		SCM-E-11-8, slotted head screw M 4x10 (s.st.) vis CM 4x10 (inox) Zylinderschraube M 4x10 DIN 85-A2		2
	D-228122-1	booster, assy. (incl. items No. 4,7,10,11,12,13) chaudière, ens. (compr. réf. 4,7,10,11,12,13) Boiler, kompl. (inkl. Teile Nr. 4,7,10 - 13)	4,5 kW, 220/50/1	1
	D-228122-2	booster, assy. (incl. items No. 4,7,10,11,12,13) chaudière, ens. (compr. réf. 4,7,10,11,12,13) Boiler, kompl. (inkl. Teile Nr. 4,7,10 - 13)	4,5 kW, 240/50/1	1
	D-228122-3	booster, assy. (incl. items No. 4,7,10,11,12,13) chaudière, ens. (compr. réf. 4,7,10,11,12,13) Boiler, kompl. (inkl. Teile Nr. 4,7,10 - 13)	6 kW, 220 V	1
	D-228122-4	booster, assy. (incl. items No. 4,7,10,11,12,13) chaudière, ens. (compr. réf. 4,7,10,11,12,13) Boiler, kompl. (inkl. Teile Nr. 4,7,10 - 13)	6 kW, 240 V	



Water Feed Pipework (Models with booster)
Conduite de Raccordement d'Eau
(Modèles avec chaudière)
Wassierzulaufleitung (Modelle mit Boiler)

WM-2E

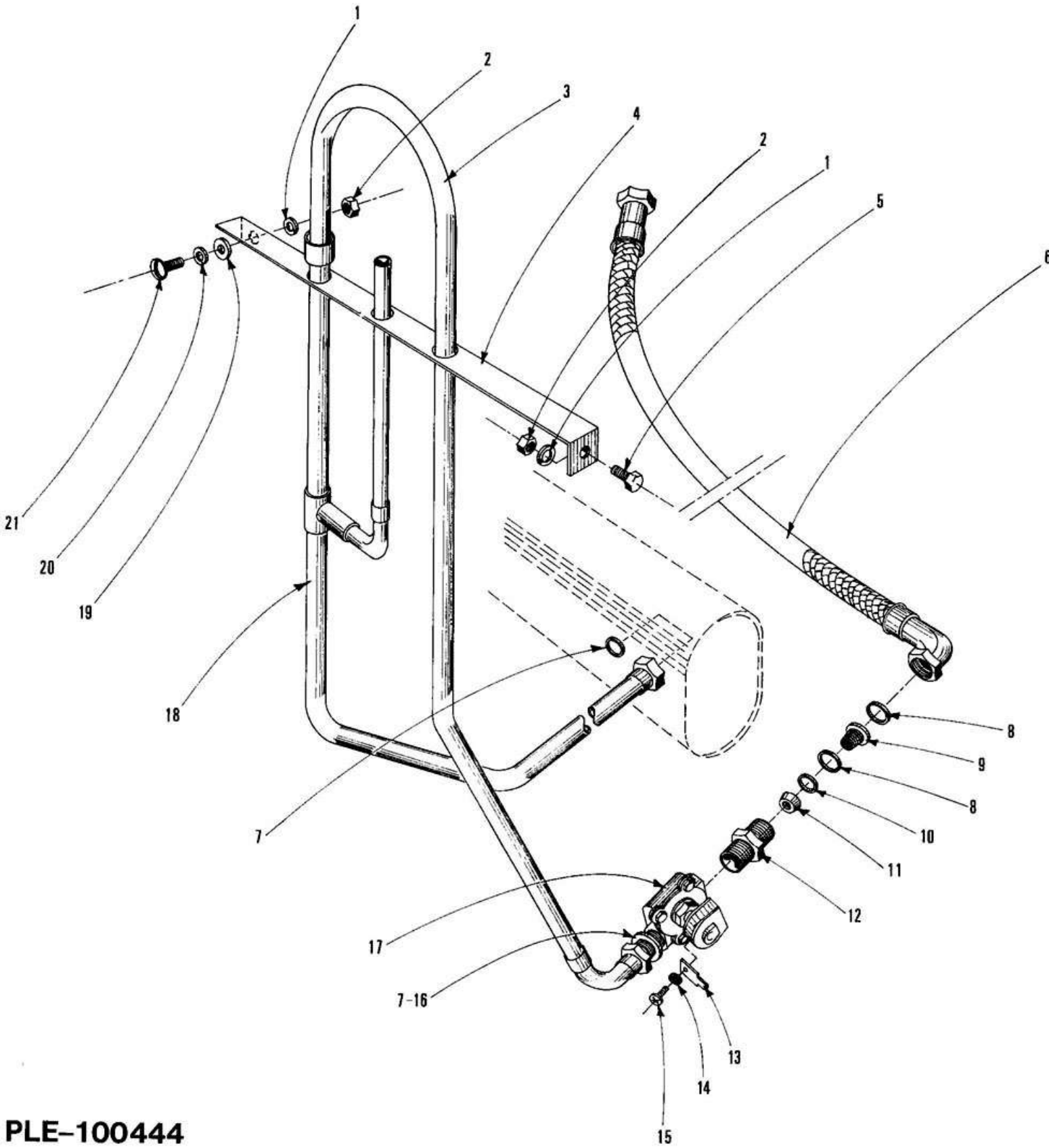

PLE-100444

key no. réf. Pos.-Nr.	part no. pièces no. Teile-Nr.	part name nom de la pièce Teile-Benennung	qty. qté. Stck.
1		LWM-E-3-1, single coil lockwasher M 6 (s.st.) rondelle WZ 6 (inox) Federring B 6 DIN 127-1,4310	2
2		NUM-E-3-2, hex. nut M 6 (s.st.) écrou H M 6 (inox) Sechskantmutter M 6 DIN 934-A2	2
3	D-228041	vacuum breaker pipe, assy. tuyau aérateur, ens. Belüfter-Rohr, kompl.	1
4	C-228039	angular tin cornière Winkelstück	1
5		SCM-E-13-10, hex. head screw M 6x10 (s.st.) vis HM 6x10 (inox) Sechskantschraube M 6x10 DIN 933-A2	1
6	C-227973-1	flexible metal hose tuyau métallique Metallschlauch	1
7	B-168611-9	gasket joint Dichtung	2
8	A-165178	rubber gasket joint caoutchouc Gummidichtung	2
9	Bk-227984	filter basket panier filtre Korbfilter	1
10	A-172511-1	flow control régulateur de débit 1 - 6 bar Mengenregler	1
11	B-227985-1	constant holder for feed pressure stabilisateur de pression d'entrée 0,2 - 0,25 bar Konstanthalter für Eingangsdruck	1
12	B-227945	nipple union mamelon de jonction Anschlußnippel	1
13	A-166157	tab cosse plate Flachstecker	1
14		external toothed lockwasher, M4 rondelle DE 4 Zahnscheibe J 4,3 DIN 6797-vern.	1
15		SD-E-1-1, M 4 G.K.N. Taptite x 12 long vis auto-tar. CM 4x8 Linsen-Schneidschraube AM 4x8 DIN 7516-vern.	1
16	B-227944	double nipple mamelon double Doppelnippel	1
17	D-228033-1	solenoid valve électrovanne Magnetventil	220/50/1 1
17	D-228033-2	solenoid valve électrovanne Magnetventil	296086-2 PLASTIC VALVE 1
18	D-228037	pipe vacuum breaker, assy. (incl. item No.4) tube aérateur, compl. (compr. réf. 4) Belüfter-Rohr, kompl. (inkl. Teil Nr. 4)	1
19	B-227087	washer gasket rondelle joint Dichtungsscheibe	1
20		WAM-E-8-28, plain washer M 6 (s.st.) rondelle M 6N (inox) Scheibe A 6,4 DIN 125-A2	1
21		SCM-E-5-7, slotted mushroom head screw M 6x10 (s.st.) vis RL M 6x10 (inox) Becherschraube M 6x10 DIN 933-A2	1
	B-228064-1	solenoid valve, assy. (incl. items No. 12-17) électrovanne et raccord, ens. (compr. réf. 12-17) Magnetventil mit Anschlußstück (inkl. Teile Nr. 12-17)	220/50/1 1
	B-228064-2	solenoid valve, assy. (incl. items No. 12-17) électrovanne et raccord, ens. (compr. réf. 12-17) Magnetventil mit Anschlußstück (inkl. Teile Nr. 12-17)	240/50/1 1



Water Feed Pipework (Models without booster)
Conduite de Raccordement d'Eau
(Modèles sans chaudière)
Wasserzulaufleitung (Modelle ohne Boiler)

WM-2E

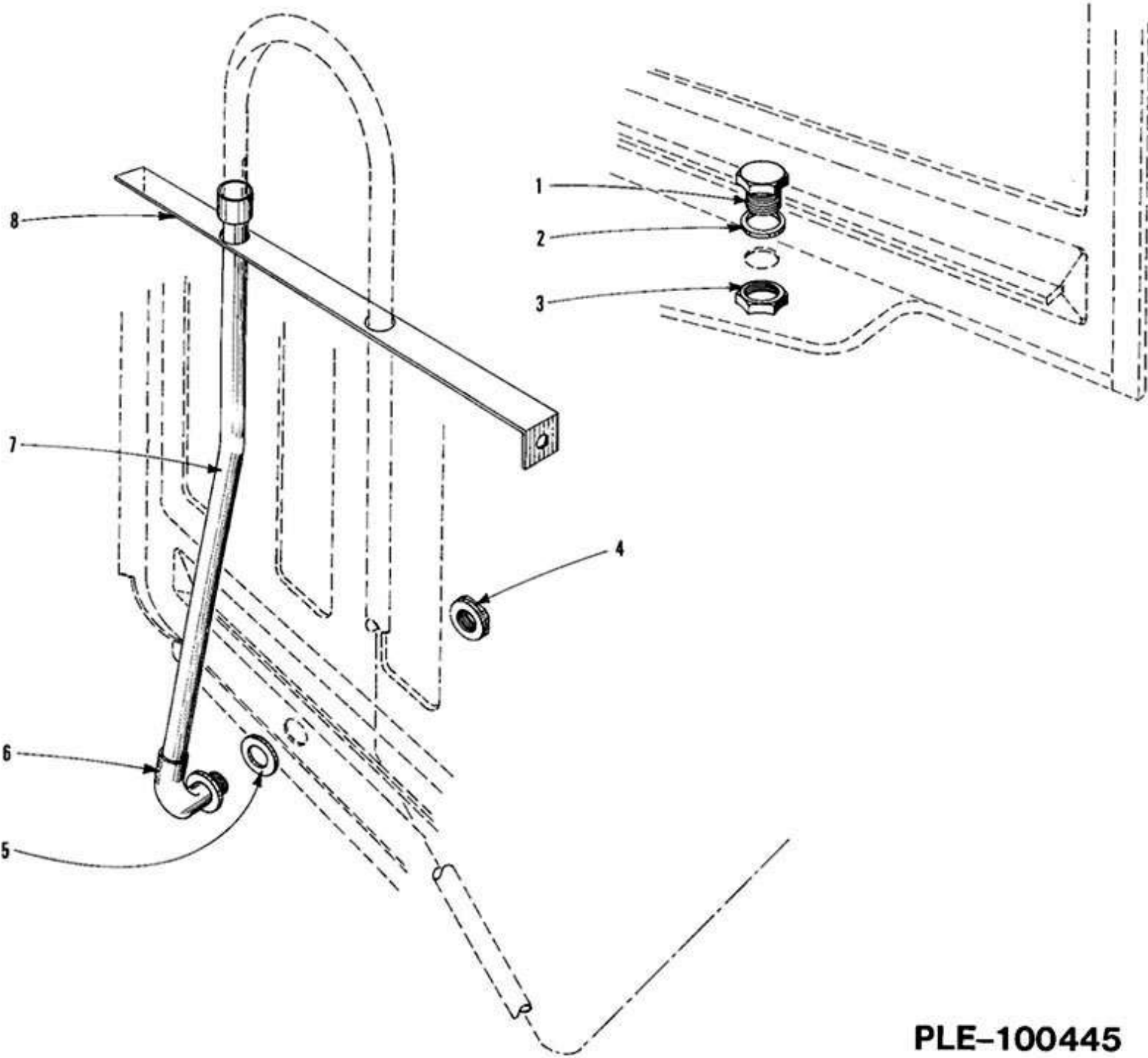

PLE-100445

HOBART

Water Feed Pipework (Models without booster)
Conduite de Raccordement d'Eau
(Modèles sans chaudière)
Wassierzulaufleitung (Modelle ohne Boiler)

WM-2E

key no. réf. Pos.-Nr.	part no. pièces no. Teile-Nr.	part name nom de la pièce Teile-Benennung	qty. qté. Stck.
1	B-228065-1	plug bouchon Stopfen	1
2	B-168611-12	gasket joint Dichtung	1
3		back nut contre-écrou Gegenmutter 3301-1/2"	1
4	B-166165	nut écrou Mutter	1
5	B-172513	gasket joint Dichtung	1
6	A-166460	junction elbow - fill coude MF de jonction - remplissage Anschlußstück - Füllung	1
7	D-228038	copper pipe tube coudé Kupferrohr gebogen 18 x 1 bended	1
8	C-228039	angular tin cornière Winkelstück	1
	D-228044	hot water pipe, assy. (incl. items No. 6,7,8) tuyau d'arrivée eau chade, compl. (compr. réf. 6,7,8) Heißwasser-Zulaufrohr, kompl. (inkl. Teile Nr. 6,7,8)	1

HOBART

Rinse Agent Dispenser
Doseur de produit mouillant
Dosiergerät

WM-2E

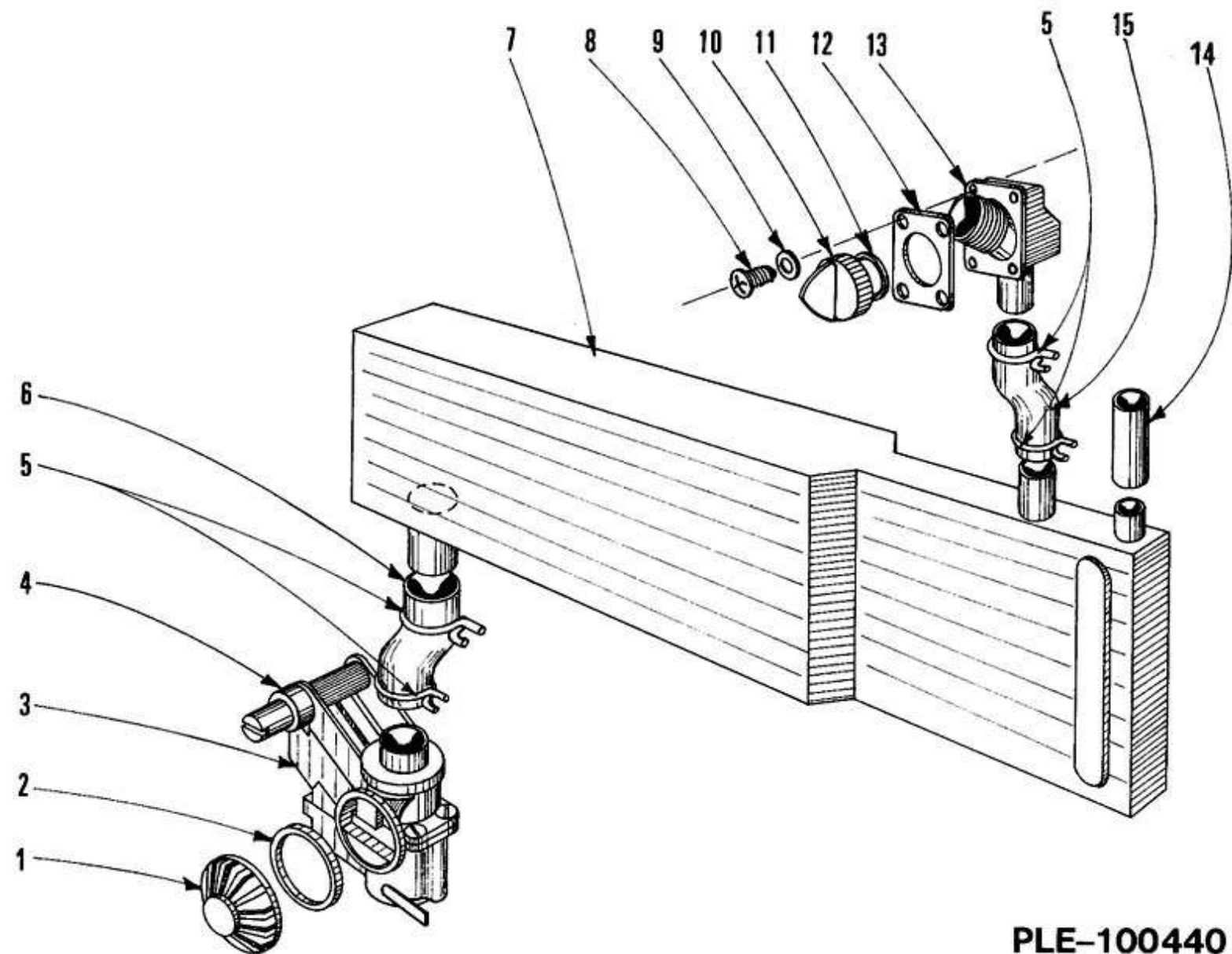

PLE-100440

key no. réf. Pos.-Nr.	part no. pièces no. Teile-Nr.	part name nom de la pièce Teile-Benennung		qty. qté. Stck.
1	A-166166	perforated cap capuchon perforé Deckel gelocht		1
2	B-172513	gasket joint Dichtung		1
3	C-165479-1	rinse agent dispenser (incl. items Nr. 1 to 4) doseur de produit mouillant (compr. réf. 1-4) Nachspülmittel-Dosiergerät (inkl. Teile Nr. 1-4)	220/50/1	1
4	A-165576	gasket joint Dichtung		1
5	M-86012	clamp-hose serre-tuyau Schlauchschelle		4
6	B-172525-1	hose tuyau Schlauch		1
7	D-227892	container réservoir Netzmittelbehälter		1
8	SD-17-42	self-tapping screw vis à tôle auto-taraudeuse Blechschaube		4
9	B-240345	flat washer (special) rondelle plate Flachscheibe		4
10	B-227883	cover couvercle Deckel		1
11	D-67500-79	«o»-ring joint torique «O»-Ring	20,35 x 1,78	1
12	B-227752	gasket joint Dichtung		1
13	C-227751	fill nozzle bouchon de remplissage Einfüllstutzen		1
14	B-165168-3	hose tuyau Schlauch		1
15	B-226111-2	hose tuyau Schlauch		1



Dispenser (option)
Doseur (sur demande)
Dosiergerät (auf Anfrage)

WM-2E

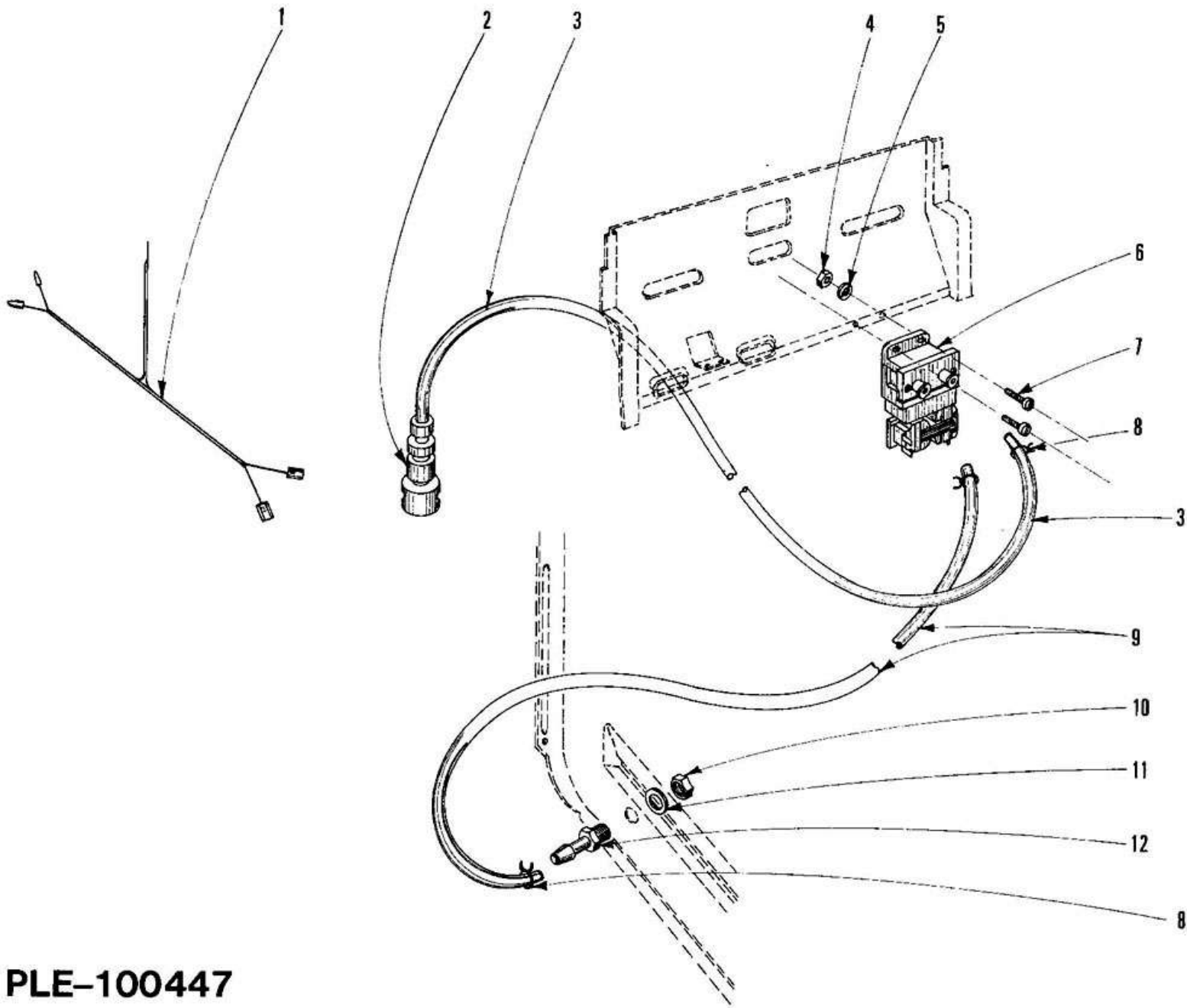

PLE-100447



Dispenser (option)
Doseur (sur demande)
Dosiergerät (auf Anfrage)

WM-2E

key no. réf. Pos.-Nr.	part no. pièces no. Teile-Nr.	part name nom de la pièce Teile-Benennung	qty. qté. Stck.
1	C-228181	wiring harness faisceau de câbles Leitungssortiment	1
2	B-227441	retaining valve clapet de fond Fußventil	1
3	A-165168-1	hose PVC tuyau PVC PVC Schlauch	1
4	NUM-E-2-6,	hex. nut M 4 (s. st.) écrou H M4 (inox) Sechskantmutter M4 DIN 934-A2	2
5	LWM-E-2-2,	single coil lockwasher M 4 (s.st.) rondelle WZ 4 (inox) Federring B4 DIN 127-1,4310	2
6	C-228022-1	hose pump pompe à tuyau Schlauchpumpe	220 -240/50/1 1
7	SCM-E-11-14,	cheese head screw M 4x16 (s.st.) vis C, M 4x16 (inox) Zylinderschraube M 4x16 DIN 85-A2	2
8	B-228070-1	clamp hose collier Schlauchklemme	3
9	A-165168-4	hose PVC tuyau PVC PVC Schlauch	1
10		union nut AR 1/8" écrou union AR 1/8" Rohrmutter AR 1/8" DIN 431	1
11	B-168611-13	gasket joint Dichtung	1
12	B-228184.	fill nozzle pipe de déversement Füllstutzen	1



Supporting Frame
Bâti inférieur
Untergestell

WM-2E

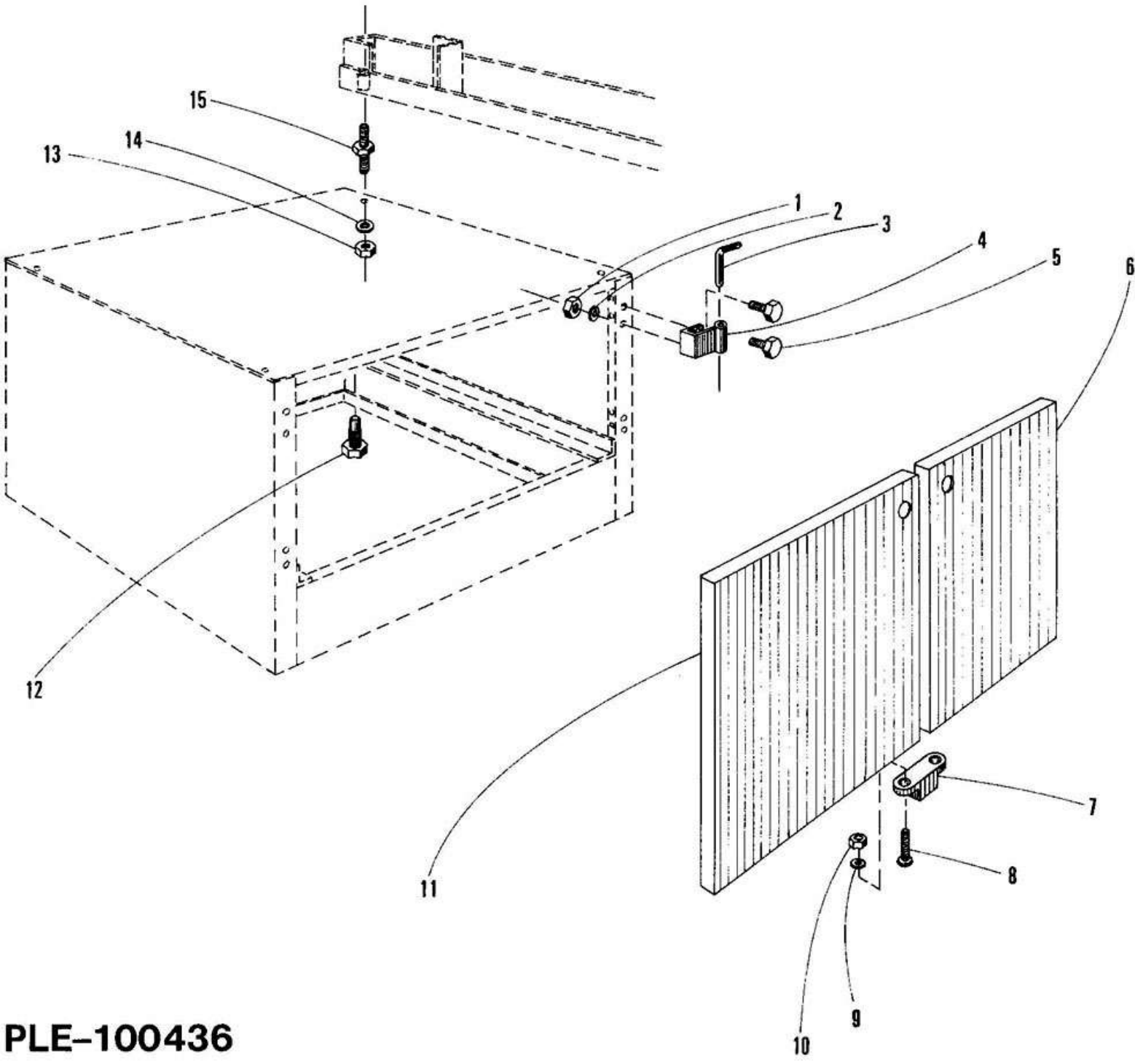

PLE-100436

key no. réf. Pos.-Nr.	part no. pièces no. Teile-Nr.	part name nom de la pièce Teile-Benennung	qty. qté. Stck.
1		NUM-E-2-27, hex. nut, M 5 (s.st.) écrou H M 5 (inox) Sechskantmutter M 5 DIN 934-A2	8
2		LWM-E-2-28, single coil lockwasher M 5 (s.st.) rondelle WZ 5 (inox) Federring A 5 DIN 127-1, 4310	8
3	B-228129	bolt axe Bolzen	4
4	B-228133	hinge charnière Scharnier	4
5		SCM-E-12-10, hex. hd. screw M 5x16 (s.st.) vis H M 5x16 (inox) Sechskantschraube M 5x16 DIN 933-A2	8
6	C-228101	door, assy. (R.H.) porte, ens. côté droit Tür, kompl., rechts	1
7	B-34651-1	magnetic catch aimant Magnet	2
8		SCM-E-1-21, slotted cheese head screw M 3x10 (s.st.) vis C.M 3x10 (inox) Zylinderschraube M 3x10 DIN 84-A2	4
9		LWM-E-1-1, single coil lockwasher M 3 (s.st.) rondelle WZ M 3 (inox) Federring B 3 DIN 127-1,4310	4
10		NUM-E-1-3, hex. nut M 3 (s.st.) écrou H M 3 (inox) Sechskantmutter M3 DIN 934-A2	4
11	C-228102	door, assy. (L.H.) porte, ens., côté gauche Tür, kompl., links	1
12	B-226945	foot - leveling bolts pied réglable Verstellfuß	4
13		NUM-E-4-27, hexagon nut M 12 (s.st.) écrou H M 12 (inox) Sechskantmutter M 12 DIN 934-A2	4
14		WAM-E-8-44, plain washer M 12 (s.st.) rondelle M 12N (inox) Scheibe B 12 DIN 125-A2	4
15	B-228167	junction bolt boulon de jonction à double filetage Verbindungsteil	4

HOBART

Racks
Paniers
Geschirrkörbe

WM-2E

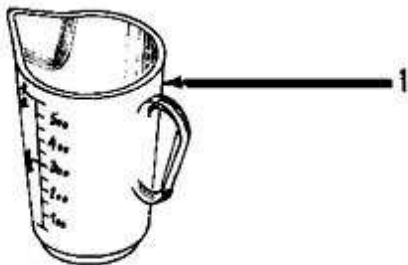
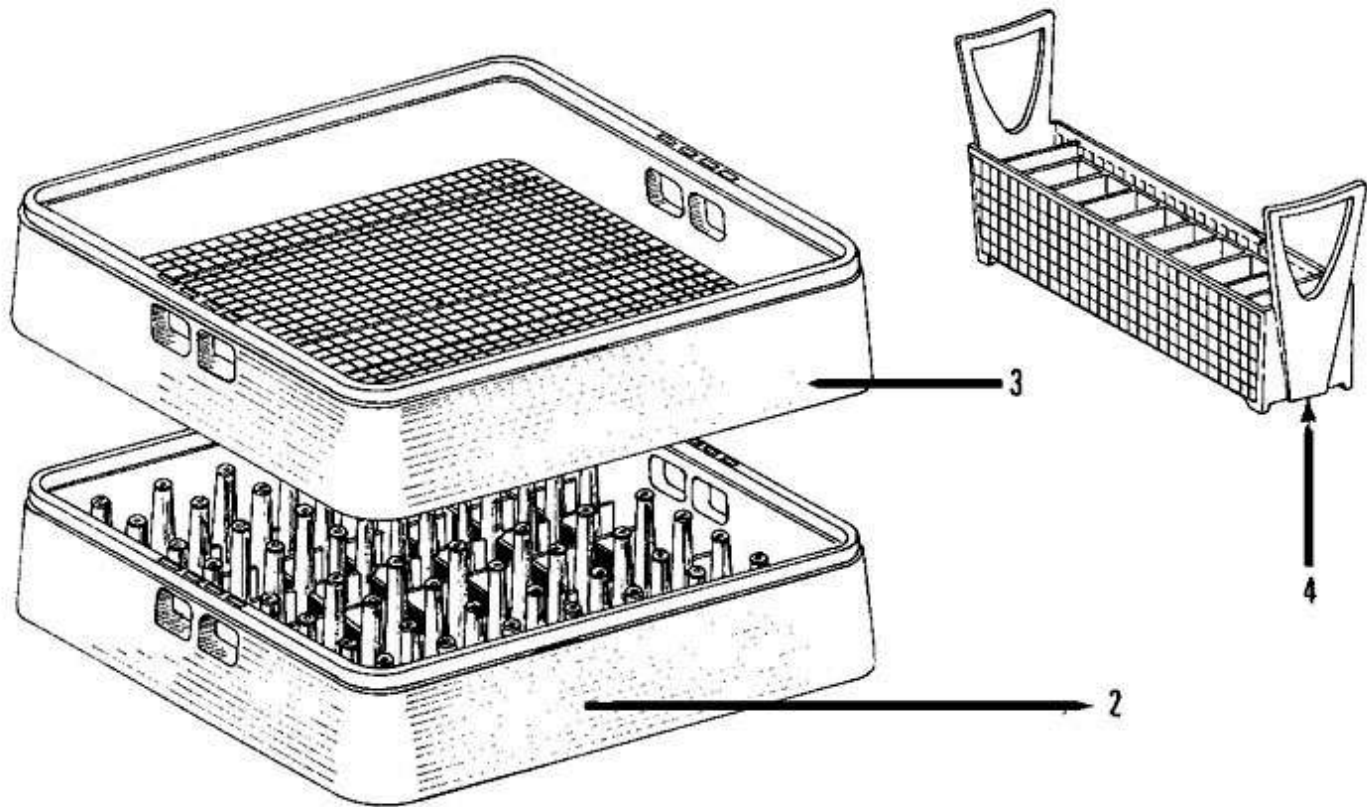

PLE-100442

HOBART**Racks
Paniers
Geschirrkörbe****WM-2E**

key no. réf. Pos.-Nr.	part no. pièces no. Teile-Nr.	part name nom de la pièce Teile-Benennung	qty. qté. Stck.
1	B-228086	measuring vessel récipient doseur 1/2 l Messbecher	1
2	P-1700	plate rack casier à assiettes Tellerkorb	1
3	P-6200	glass and cup rack casier à fond plat Gläser- und Tassenkorb	1
4	E-101296	silverware basket casier à couverts Besteckkorb Besteckkorb	1